



# PTE 30 Mini

## Electric Low-Lift Power Pallet Truck 24-Volt

### CAPACITY

3000 lbs.

### BATTERY—CHARGER

24-volt industrial battery pack with (2)12V 95AH maintenance free batteries. Matching external 8A SCR charger 110VAC plug-in. Minimum battery weight 200 lbs.

### SPEED

**Curtis** SepEx™ transistor speed control

Variable from 0 mph to 3.66 mph empty  
Variable from 0 mph to 2.86 mph loaded

### WEIGHT

630 lbs with battery

### TIRES / WHEELS

DRIVE

10" x 2.5" polyurethane

LOAD

3.15" x 4.75" polyurethane

STABILITY & FORKS

4" Diameter stability caster wheels

Phenolic "pallet" entry wheels

### HYDRAULICS

Heavy duty pump motor with relief valve protects system from overloading.

### ELECTRICAL

Advanced **Curtis** drive controller provides smooth step-less acceleration with infinitely variable speed control. Anti-rollback feature delivers maximum power when required for uphill or down-hill gradients Fully programmable.

### BRAKES

Electromagnetic disc brake connected to drive shaft. Adjustable neutral braking, plugging, and regenerating braking are standard. "Dead-man" emergency brake with power cutoff.

### CONTROLS

Travel lift and lower functions are located in the ergonomic operator handle designed to allow operation with either hand. Wrap around hand guard, reversing switch, dual "butterfly" thumb control, and horn are standard.



### TRANSMISSION

Durable long life low noise gearbox with Long life precision ground gears.

### ACCESSIBILITY

Removal of one piece power head cover exposes major components for inspection and maintenance. Drive tire can be removed with one nut.

### STANDARD EQUIPMENT

- Curtis Transistor Travel Controller
- "Butterfly" Travel Thumb Control
- Key Switch and Horn Button
- Combo Gauge—Hour Meter with Battery Discharge Indicator (BDI)
- Reversing Switch in Handle
- Stability Casters
- Pallet "Entry" Wheels

# PTE 30



## Electric Low-Lift Power Pallet

## Electric Power Pallet Truck

Control Handle  
Wraparound Hand  
Guard



Big Joe  
Product Support



Pallet Entry  
Rollers

-Standard-  
Hour Meter  
BDI Combo Gauge

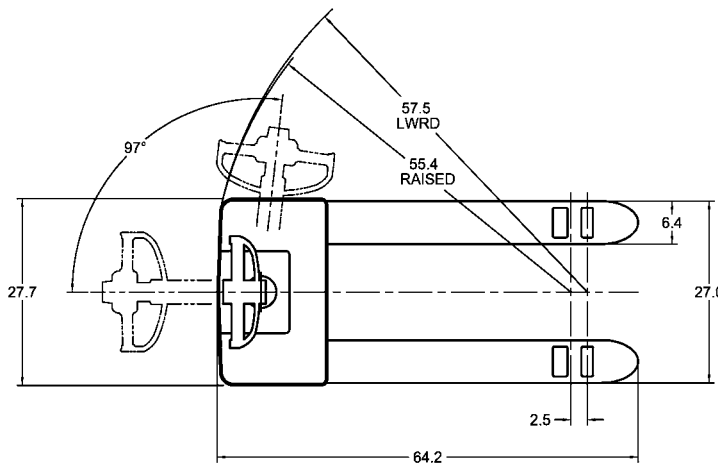

Pallet Width	Pallet Length					
	36		42		48	
	A	B	A	B	A	B
36	61	38	63	52	69	55
40	61	42	64	54	68	57
42	61	44	64	58	69	58
48	62	50	64	58	70	62
60	63	50	65	69	71	72

Note: Data shown in inches.  
Dimensions shown are zero clearance. Add 6-12" for maneuvering.

A - Right Angle Stack  
B - Intersecting Aisle

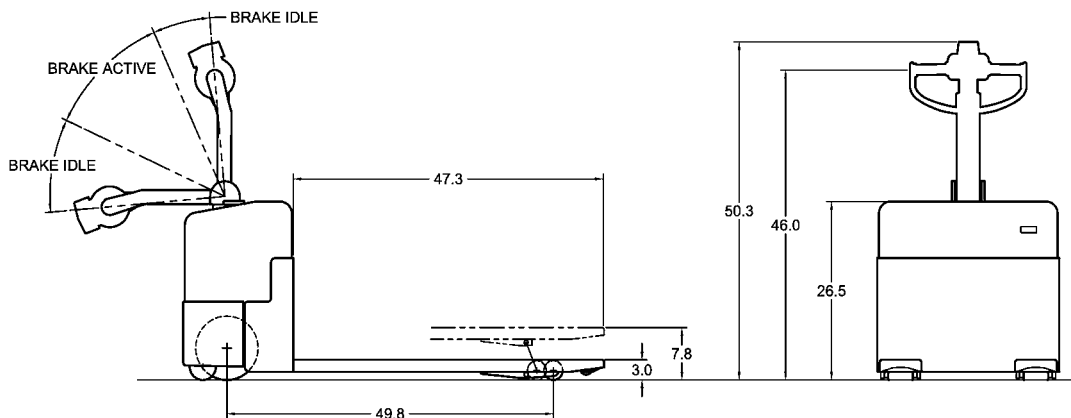
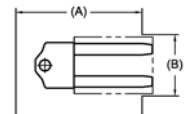

*Not... Your ...Average...Joe*

**Big Joe Manufacturing Company, Inc.**  
1700 Higgins Road Suite 200  
Des Plaines, IL 60018  
Phone: 847-298-9800  
Fax: 847-298-6362  
www.bigjoemfg.com

**Certification**  
All units are built to be in compliance with the Occupational Safety & Health Act (OSHA)  
Big Joe Manufacturing Company will not assume liability for injuries or damage arising from, or caused by, the removal of any safety devices from their vehicles by user. Because of the Big Joe Policy of continuing product improvements, specifications are subject to change without notice.

© Copyright 2007, Big Joe Manufacturing Company, Des Plaines, IL 60018 Printed USA 0607