



# CB22

## Counterbalanced Walkie Stacker



### CAPACITY

2200 lbs. at 24" load center

### BATTERY

Compartment: 26.78" x 9.06" x open. Anderson 175 Gray—A-11 Minimum battery weight 340 lbs.

### SPEED

24-volt ZAPI ACO Travel Controller

### TRAVEL

Variable from 0 mph to 3.4 mph empty  
Variable from 0 mph to 3.1 mph loaded

### TILT

4° Back 2° Forward (loaded cap)

### LIFT

Up to 33 fpm empty.  
Up to 25 fpm loaded

### LOWERING

Up to 29 fpm empty.  
Up to 57 fpm loaded

### TIRES / WHEELS

#### DRIVE

9" x 3" polyurethane

#### LOAD

10" x 4" polyurethane

### HYDRAULICS

Lift cylinder is hard chrome. Self contained hydraulic power unit. Pressure compensated lowering valves regulates lowering speeds.

### ELECTRICAL

ZAPI AC travel controller and AC drive motor provides high torque throughout the entire drive range. Regenerative braking and brushless design drastically reduces maintenance.

Travel speed remains constant relative to throttle position regardless of the load on truck. EPD with built in line contactor.

### BRAKES

Electromagnetic brake is mounted on motor armature shaft multiplying the braking power through the ZF ZK10 transmission.

Brake is applied when control arm is in the vertical or horizontal handle position. Travel speed is reduced when forks are above 12" fork height. Position hold resists roll back on ramps.

### CONTROLS

Travel, lift, lower and tilt functions are located in the ergonomic operator handle, designed to allow operation with either hand. Wrap around guard, reversing switch, thumb control, and horn are standard.

### TRANSMISSION

Vertically mounted drive motor is direct mounted to gear housing. Oil bathed bevel gear drive-train transfers power to axle. State of the art optimized gear technology supplies advantages such as zero maintenance, low noise level, high efficiency and high performance.

### FRAME AND MAST

Bolt-on high visibility I-beam construction, lift cylinders are positioned in outer I-beam for good operator visibility through mast. Dual lifting chains.

Class two ITA fork carriage with 36" tall load back rest.

### BEARINGS

DRIVE WHEEL-Tapered roller bearings sealed in oil bath

LOAD WHEELS-Sealed ball bearings

### ACCESSIBILITY

Removal of two piece power head cover exposes major components for inspection and maintenance.

### STANDARD EQUIPMENT

- Regenerative Braking
- Gas Assist Spring Handle
- Low Battery Interrupt
- Hour Meter BDI Combo Gauge
- Key Switch
- 36" Tall Load Backrest

### OPTIONAL EQUIPMENT

- Industrial Battery 255 AH 5.9 kwh

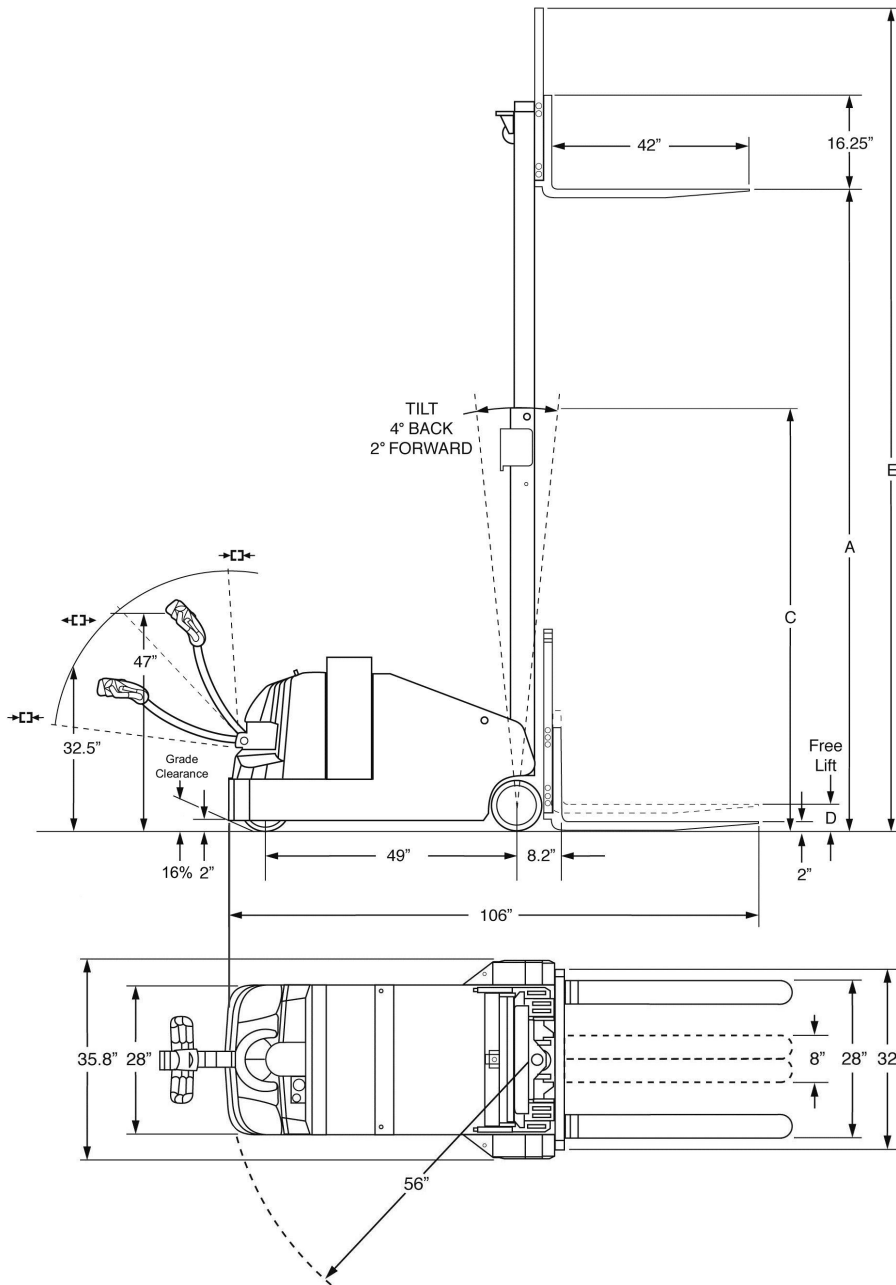

### Aisle Guide

CB22 - Right Angle Stacking

Load Width	Load Length		
	36"	40"	48"
36"	115"	120"	125"
40"	115"	120"	125"
48"	115"	120"	125"

For ease of use add 6 to 12" to aisle dimension listed

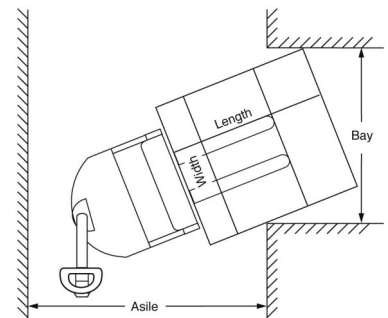

Aisle dimensions listed above assume 4" between loads. Use the larger dimension; load width or load length. For ease of use and add 6" to 12" for operator clearance to the appropriate specifications listed above. Truck performance may vary due to application requirements' and changes in model design.

Add: 2" to aisle for model CB22-157 with triple stage mast.

Model #	Mast	Lift Height	Col Height	Free Lift	Ext Height w/LBR	Gradability		<sup>3</sup> Weight Chassis Only
		A	C	D	E	Loaded	Unloaded	
<b>2200 Capacity @ 24" Load Center ITA Class II Fork Carriage</b>								
CB 22-104	Two Stage	104	72.3	6	143	5%	8%	4005
CB 22-128	Two Stage	128	83.2	6	165	5%	8%	4082
CB 22-157*	Triple Stage	157	71.0	50	193	5%	8%	4422

\*Derate 400 lbs. above 128" w/ 224AH battery pack.  
\*Consult factory for derate with industrial battery.

<sup>3</sup> Estimated shipping weight without battery

