

EKKO[®]

MATERIAL HANDLING EQUIPMENT

MOVING AHEAD

4-WHEEL ELECTRIC FORKLIFT EK20R SERIES

- Load Capacity 4500 lbs.
- Lift Height 189-216 in. 3 Stage
- Side Shifting Forks
- 48V420Ah Industrial Batteries
- Free Lift 68-77"
- Hydraulic Power Steering
- Length 129"
- Curtis Controller
- Tilt 3/6 degree
- Mast Height 84-93"
- Overhead Guard 86.5"
- Batteries & Charger
- 3 Year Limited Warranty



EK20R

Superior quality, maneuverable, compact, and durable for all your material handling applications. Ideal for small aisles and areas.

WEIGHT CAPACITY: 4500 lbs. @ 24" load center

LIFT HEIGHT: 189-216 3 Stage

SIDE SHIFTING FORKS: 45.3"

MAST HEIGHT: 84-93"

TURNING RADIUS: 84.6"

FREE LIFT: 68-77"

TILT: 3/6 degree

INDUSTRIAL BATTERY / CHARGER: 48V 420Ah, Industrial batteries with external direct connect 210A 210VAC plug-in automatic 48V/65A charger (both Included)

BRAKING: Drum brakes

SPEED TRAVEL: 9 mph empty ; 7.5 mph loaded

LIFTING SPEED: 16 ips empty; 9.9 ips loaded

LOWERING SPEED: 10.2 ips empty; 9.5 ips loaded

FRONT WHEELS: 6.5x10x10" solid cushion

REAR WHEELS: 5x8x10" solid cushion

HYDRAULICS LIFTING MOTOR: 48V 7700 Watt lifting motor with hardened chrome moly steel for durability.

DRIVE MOTOR: 48V 7500 Watt ZF AC drive motor for efficiency and high torque.

AC CONTROLLER: 48V Curtis provides performance through entire range of speed; Constant travel speed regardless of load; Battery discharge indicator combination gauge.

BRAKES: Drum Brakes with Electro-magnetic braking for secure stopping power

LIGHTING: LED Head lights, turn signals and brake lights.

OPERATOR CONTROLS: Tilt, lifting, lowering, side shifting forks, horn functions are located in the ergonomic sit down; Led lighting.

CHASSIS AND MAST: Robotic Welding; Heavy duty steel chassis with I-beam mast for durability; Telescoping mast.



4-Wheel Electric Forklift

EKKO®

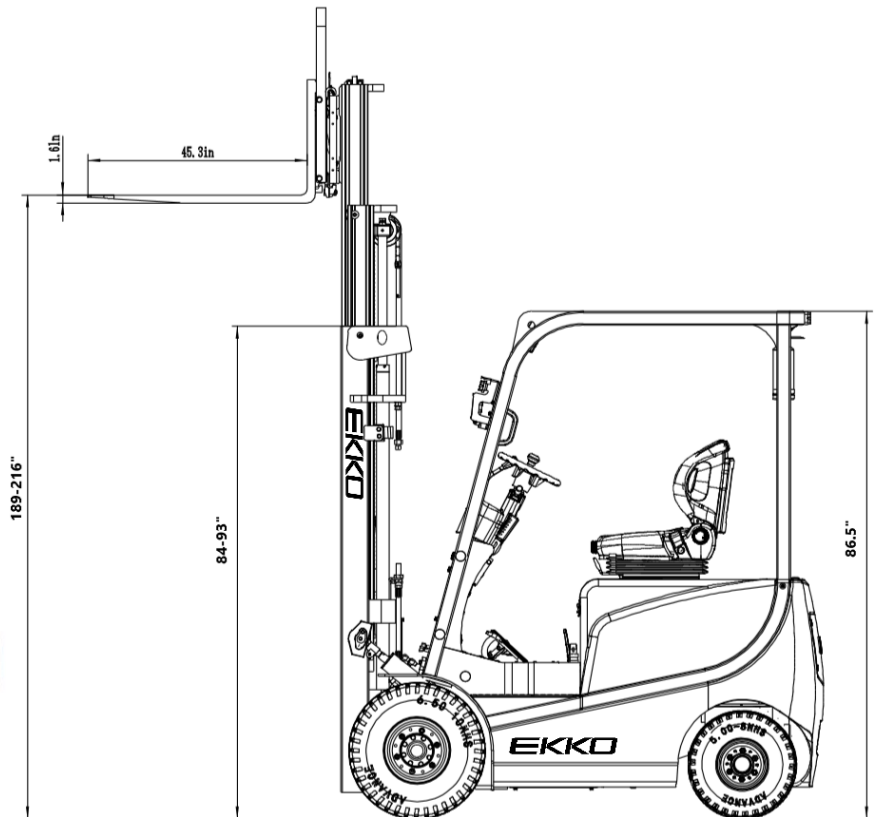
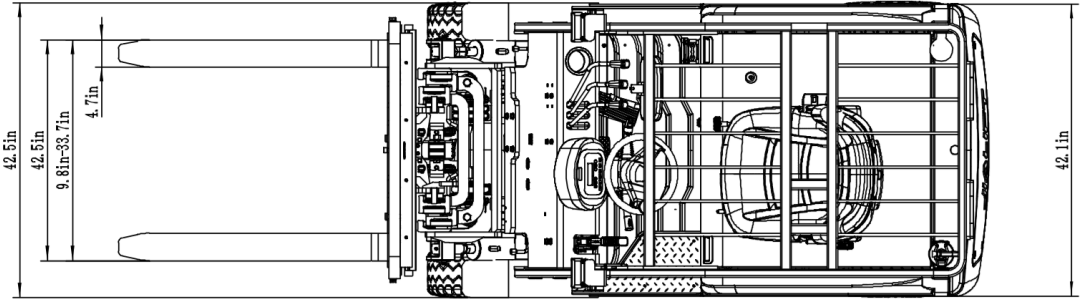

MODEL #	LOWERED MAST	LIFT HEIGHT	FREE LIFT	MAX MAST HEIGHT	TOTAL LENGTH	SERVICE WEIGHT
EK20R	93"	216"	77"	249"	129"	8000lbs
EK20RL	84"	189"	68"	221"	129"	7500lbs

EKKO®
 MATERIAL HANDLING EQUIPMENT
MOVING AHEAD

1761 W. Holt Ave.
 Pomona, CA 91768 USA
 T: (877) 232-6517 F: (909) 222-6861

AUTHORIZED DEALERS ONLY
www.ekkolifts.com