

Print Number:

Print Date:

NOBLELIFT



Scan QR Code for More

Rider scrubber

NR810

Parts Manual

590446020101

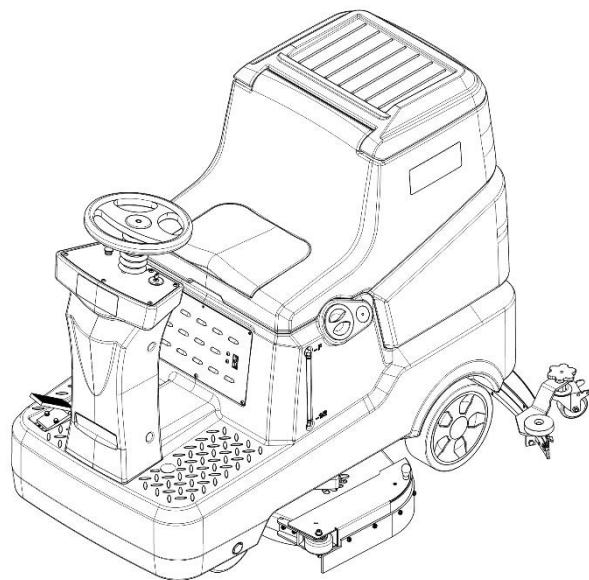

Version V05

Scrubber Identification Number From:

Parts Manual NR810-PM05EN

Please order parts from authorized dealers of our company.

In order to avoid wrong delivery, all the orders for spare parts should specify the following items:

- Truck model, identification number and manufacture year.
- Orders for spare parts of mast, hydraulic transmission unit, steering axle, motor, etc. shall indicate the manufacture number of these parts.
- Codes for our company spare parts are shown in the table of parts manual. Please also pay attention to the description of supply status, order quantity, etc. (check the number listed in "Mark" column of the parts manual).

"Mark" Column:

The unmarked indicates the parts are in short supply cycle.

Number 1: supply as package. Indicating these that parts are small parts and seal parts, which are supplied in package unit and in short supply cycle.

Number 2: supply with constraints. Indicating that these spare parts are not in stock and will be prepared for production after receiving the order from customers, which are in long supply cycle.

Number 3: phasing-out supply. Indicating that these parts will be replaced by new parts due to technical improvements and the current stock will not be available when these parts run out. Please check the description of technical improvements notice.

Number 4: supply as assembly. Indicating that these parts are assembly parts defined by manufacture process, which cannot be supplied as a single part.

Number 5: check other tables.

This parts manual is the property of our company and can be shared under the confidential agreement only, our company has the right to claim for compensation of any unauthorized use. Copy without permission is not allowed. Figures in the manual are not limited by the original design. our company reserves the right to improve the products for continuous technology progress.

Table of Contents

Chapter 1: Drive system	1
01 Steering machine (590446013501)	1
02 Drive unit (590446013502)	3
Chapter 2: Truck Frame.....	5
01 Solution tank (590446021501).....	5
02 Recovery tank (590446021502)	7
03 Brush system (590446021503)	9
04 Front electric motor assembly (590446021504).....	11
05 Squeegee system (590446021505)	13
06 Solution assembly (590446021506).....	15
07 Front body (590446021507)	17
08 Retaining edge (590446021508)	19
09 Wiper frame (590446017001)	21
10 Wheels (590446017002).....	23
Chapter 3: Electrical parts.....	25
01 Electronic control components (590446033001).....	25
02 Traction Battery (590446037001)	27
03 Charger (590446036501)	29
Chapter 4: Others.....	31
01 Labels and decals (590446047001).....	31
Appendix.....	33
01 Electrical Circuit Diagram (509946045502).....	33
02 Easy Wornout Parts List.....	34
03 Consumable Parts List.....	35

Chapter 1: Drive system

01 Steering machine (590446013501)

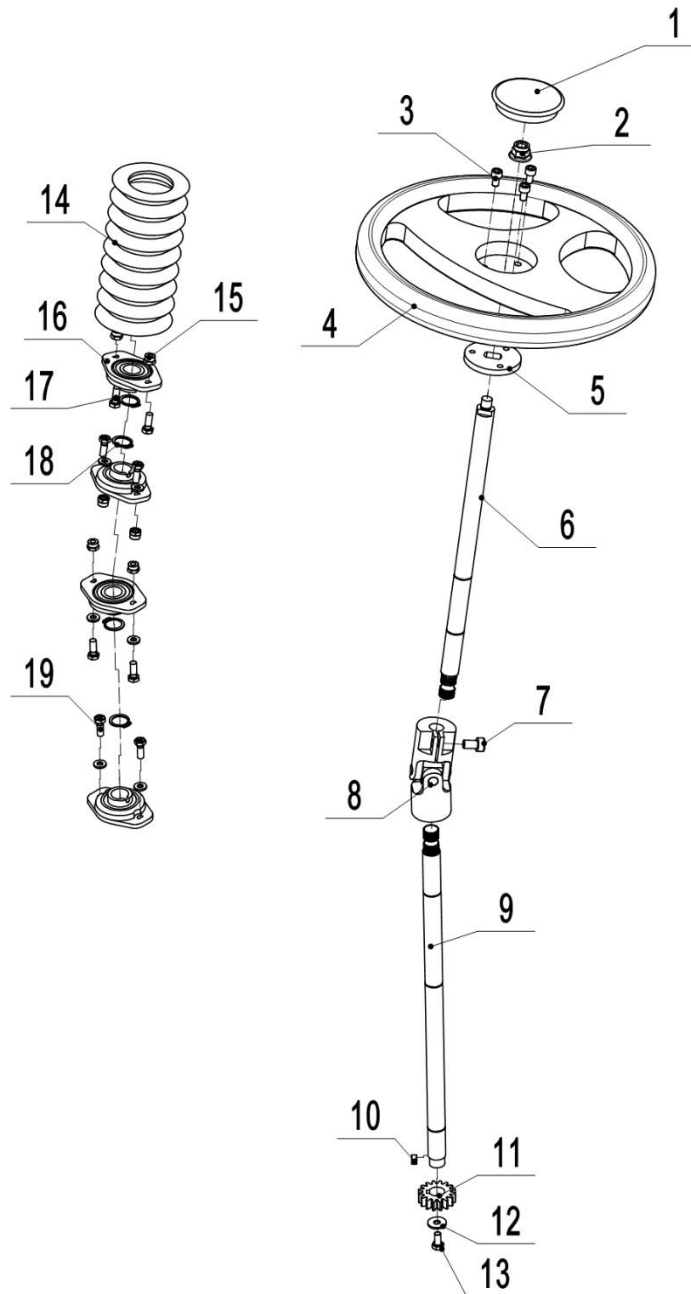

590446013501

01 Steering machine (590446013501)

No.	Item Code	Mark	Item Description	Qty.	Substitute	Note
1	590498520132		STEERING WHEEL COVER	1		
2	590198520065		NUT HEX SELF LOCKING M10	1		
3	590398520056		SCREW SOCKET HD M6x10	3		
4	590498520050		STEERING WHEEL COVER	1		
5	590398520039		HOLDER	1		
6	590498520041		TOP SHAFT	1		
7	590198520100		SCREW HEX HD M8x25	2		
8	590398520077		CARDAN	1		
9	590398520033		DOWN SHAFT	1		
10	590398520076		KEY 5x5x10	1		
11	590398520037		COG WHEEL	1		
12	590398520051		WASHER FLAT D6x20x2	1		
13	590398520055		SCREW CYL HD M6x12	1		
14	590498520137		RUBBER	1		
15	590198520067		NUT HEX SELF LOCKING M6	6		
16	590398520067		BRARING HOLDER	4		
17	590198520087		SCREW SOCKET HD M6x20	6		
18	590398520061		RETAINING RING D17	4		
19	590198520142		SCREW M6x16 W WASHER	2		

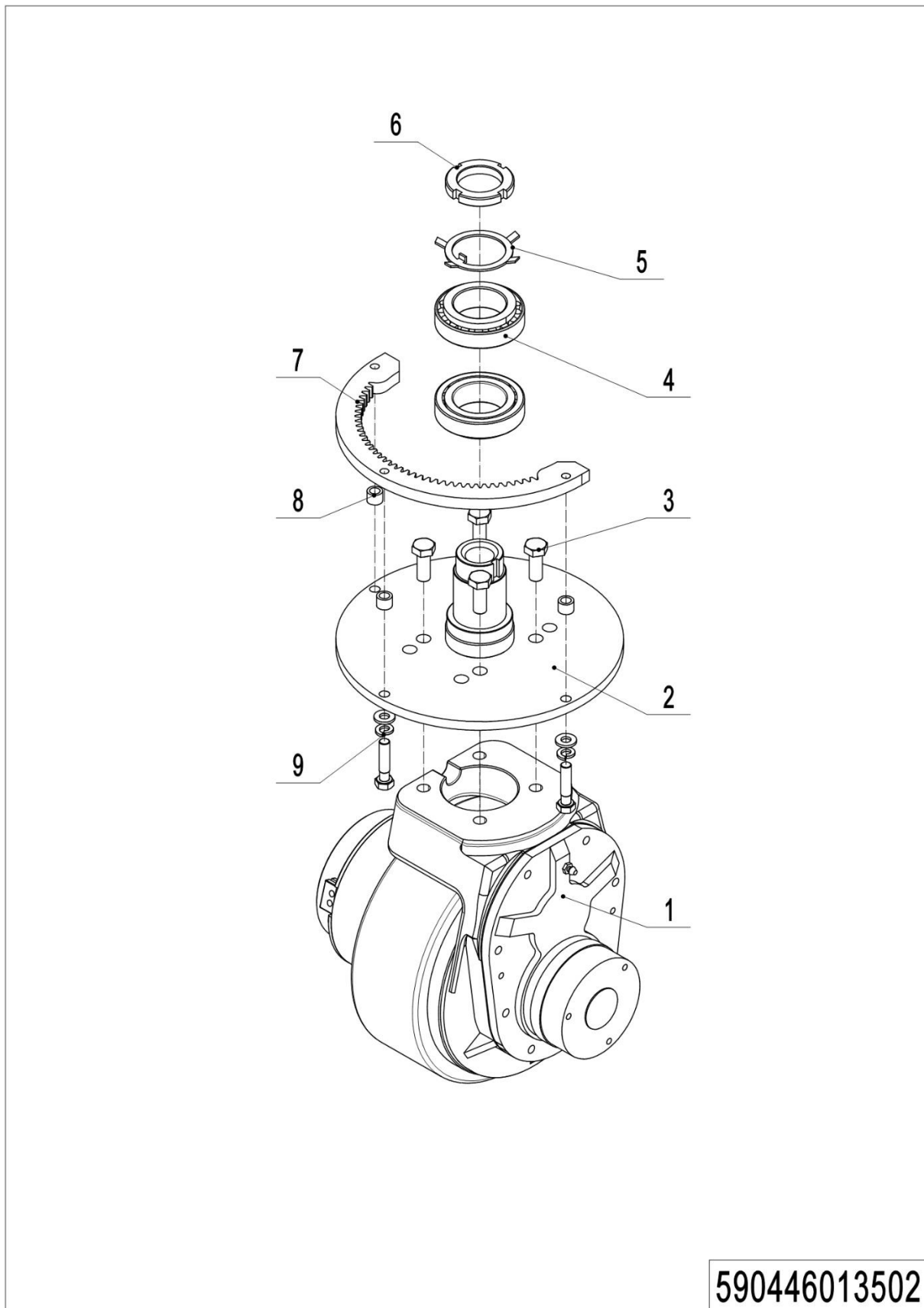
02 Drive unit (590446013502)

02 Drive unit (590446013502)

No.	Item Code	Mark	Item Description	Qty.	Substitute	Note
1	590498520056		DRIVE MOTOR 650W	1		
2	590498520029		SUPPORT FOR DRIVE MOTOR	1		
3	590198520150		SCREW HEX HD M8x35	5		
4	590398520075		BEARING	2		
5	590398520054		WASHER M36	1		
6	590398520065		NUT M36x1.5	1		
7	590498520042		GEAR RING	1		
8	590498520133		SPACER D8xD12x8	3		
9	590198520145		SCREW HEX HD M8x30	3		

Chapter 2: Truck Frame

01 Solution tank (590446021501)

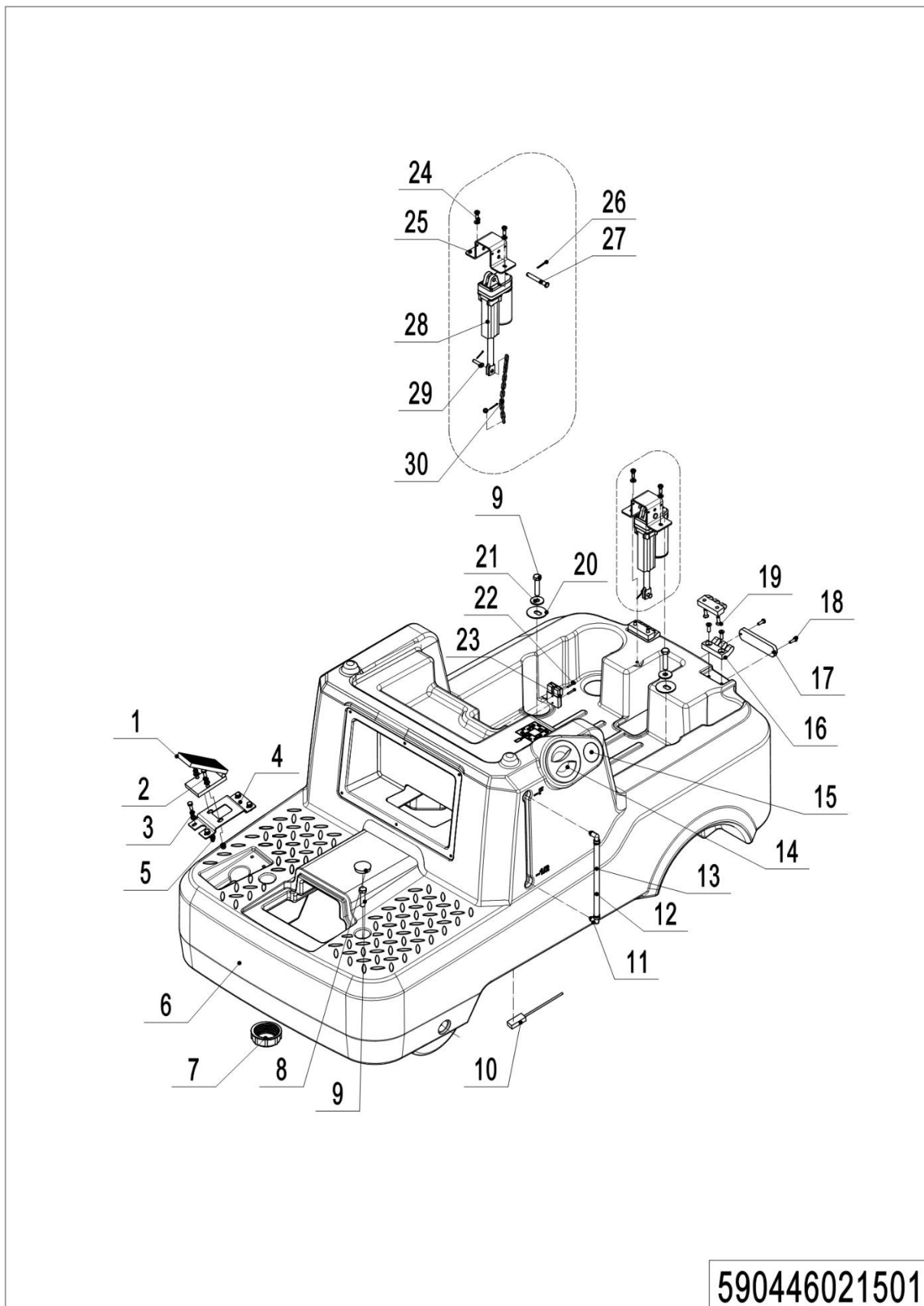

01 Solution tank (590446021501)

No.	Item Code	Mark	Item Description	Qty.	Substitute	Note
1	590398510006		ACCELERATOR	1		
2	590398520048		SCREW M6x20 W WASHER	2		
3	590198520142		SCREW M6x16 W WASHER	4		
4	590498520044		HOLDER FOR ACCELERATOR	1		
5	590198520067		NUT HEX SELF LOCKING M6	2		
6	590498510001		SOLUTION TANK	1		
7	590398520008		COVER	1		
8	590498520017		CAP	2		
9	590498520065		SCREW HEX HD M10x45	2		
10	590498520124		CLEAN WATER TANK SENSOR	1		
11	590198520128		L CONNECTOR 8	2		
12	590198520139		HOSE 8	0.4		0.4m
13	590198520130		BALL Ø6.5	1		
14	590398520007		COVER	1		
15	590498520053		HOSE FOR WATER INJECTION	1		
16	590498520126		HINGE	2		
17	590398510010		ALARM LIGHT	1		
18	590198520092		SCREW CYL HD M4x12	2		
19	590198520143		SCREW SOCKET HD M6x20	8		
20	590498520097		BIG WASHER	2		
21	590198520080		WASHER FLAT D10xD30x2.5	2		
22	590498520082		SCREW CYL HD M5x30	2		
23	590498510010		MAIN WIRE	1		
24	590198520142		SCREW M6x16 W WASHER	2		
25	590498520138		HOLDER	1		
26	590398520069		SPLIT PIN	3		
27	590498520068		SHAFT 8x60	1		
28	590498510009		REAR PUSH MOTOR	1		
29	590398520059		SHAFT 6x25	2		
30	590498520128		CHAIN	0.3		0.3m

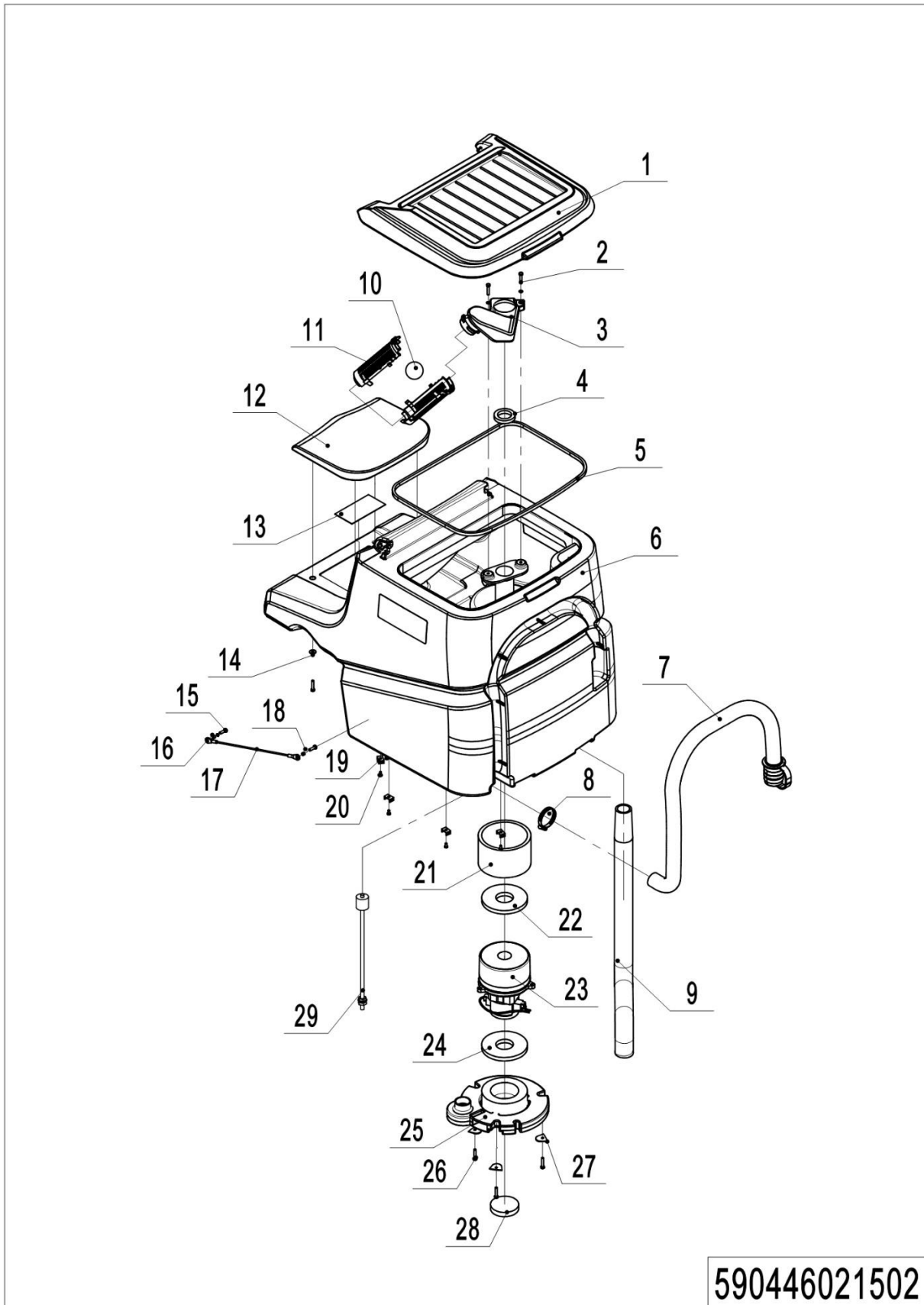
02 Recovery tank (590446021502)

02 overy tank (590446021502)

No.	Item Code	Mark	Item Description	Qty.	Substitute	Note
1	590498520022		RECOVERY TANK COVER	1		
2	590198520144		SCREW SOCKET HD M6x25	2		
3	590198520013		SUPPORT FOR CAGE	1		
4	590198520059		GASKET	1		
5	590198520061		GASKET	1.45		1.45m
6	590498520020		RECOVERY TANK	1		
7	590498520055		DRAIN HOSE	1		
8	590198520105		HOSE CLAMP D27-51	1		
9	590498520054		VACUUM HOSE	1		
10	590198520015		FLOATING BALL	1		
11	590198520014		CAGE FOR FLOATING BALL	2		
12	590398520043		SEAT	1		
13	590498520136		SENSOR FOR SEAT	1		
14	590198520085		SCREW HEX HD M6x30	4		
15	590198520083		SCREW SOCKET HD M6x16	2		
16	590398520074		SPACER	2		
17	590398520073		CABLE	1		
18	590198520079		WASHER FLAT D6xD18	11		
19	590198520095		FLAT TIE HOLDER	7		
20	590198520091		SCREW CYL HD M5x12	7		
21	590198520056		ACOUSTIC INSULATION PIPE	1		
22	590198520054		GASKET	1		
23	590498510008		VACUUM MOTOR 24V	1		
24	590198520057		GASKET	1		
25	590198520020		VACUUM MOTOR COVER	1		
26	590198520085		SCREW HEX HD M6x30	3		
27	590198520040		PLATE FOR VACUUM COVER	3		
28	590198520058		FILTER FOAM	1		
29	590498520125		SEWAGE TANK SENSOR	1		

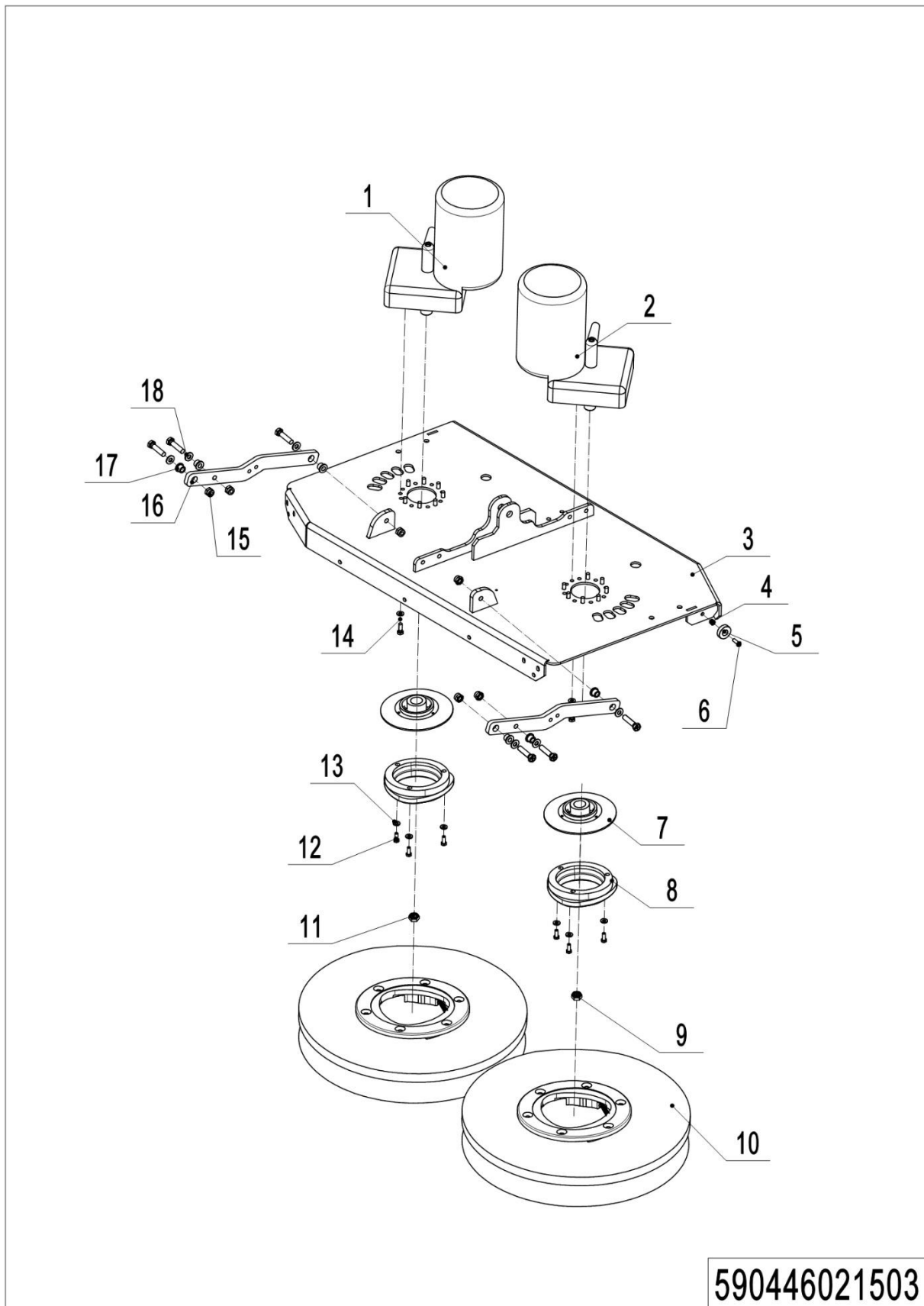
03 Brush system (590446021503)

1= Supply as package. 2= Supply with constraints. 3= Phasing-out supply. 4= Supply as assembly. 5= Check other tables.

03 Brush system (590446021503)

No.	Item Code	Mark	Item Description	Qty.	Substitute	Note
1	590498510005		REDUCTION	1		
2	590498510006		REDUCTION	1		
3	590498520030		BRUSH DECK	1		
4	590198520068		NUT HEX SELF LOCKING	2		
5	590498520077		MAGNET	2		
6	590498520067		SCREW SOCKET HD	2		
7	590198520045		NR530 LOCK DIAL	2		
8	590198520010		BRUSH DUSC TRIANGLE	2		
9	590398520064		NUT M20x1.5 (RH)	1		
10	590498510013		BRUSH	2		
10	590498520112		BRUSH(SOFT)	2		OPTIONAL
10	590498520113		BRUSH(HARD)	2		OPTIONAL
10	590498510014		MAGNETIC PAD	2		
11	590198520072		NUT M20x1.5 (LH)	1		
12	590198520087		SCREW SOCKET HD	6		
13	590198520075		WASHER SPRING M6	6		
14	590198520142		SCREW M6x16 W	8		
15	590198520066		NUT HEX SELF LOCKING	6		
16	590498520033		CONNECTION ROD	2		
17	590398520072		SPACER D8xD12x10	6		
18	590198520145		SCREW HEX HD M8x30	6		

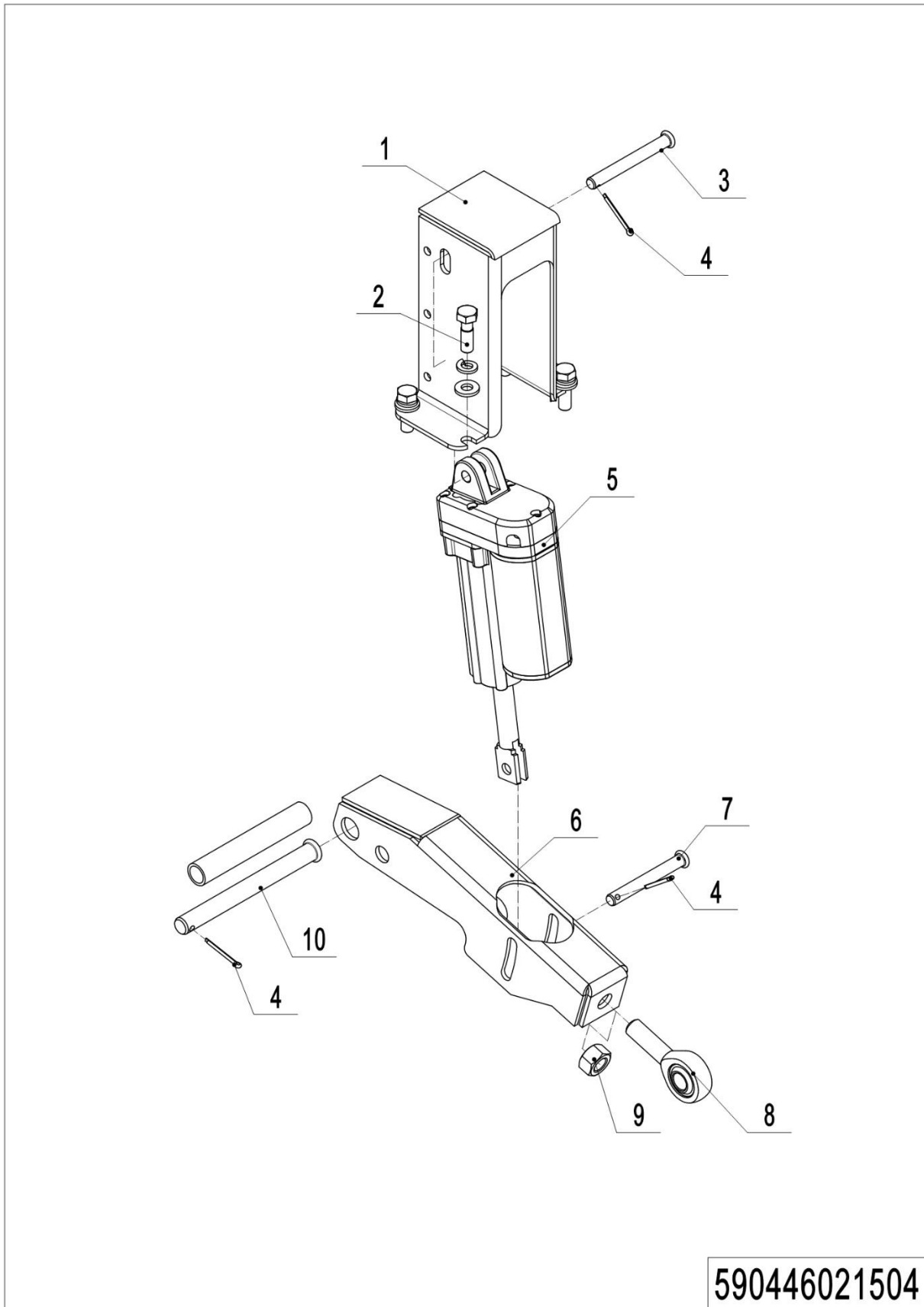
04 Front electric motor assembly (590446021504)

1= Supply as package. 2= Supply with constraints. 3= Phasing-out supply. 4= Supply as assembly. 5= Check other tables.

04 Front electric motor assembly (590446021504)

No.	Item Code	Ma	Item Description	Qty.	Substitute	Note
1	590498520037		HOLDER 1 FOR PUSH	1		
2	590398520057		SCREW M8x16 W WASHER	4		
3	590498520070		SHAFT 8x70	1		
4	590198520180		SPLIT PIN 3	2		
5	590498510004		FRONT PUSH MOTOR	1		
6	590498520034		LIFT CONNECTOR	1		
7	590498520071		SHAFT 12x45	1		
8	590498510011		ROD ENDS BEARINGS	1		
9	590498520074		NUT M12	1		
10	590498520072		SHAFT 12x120	1		

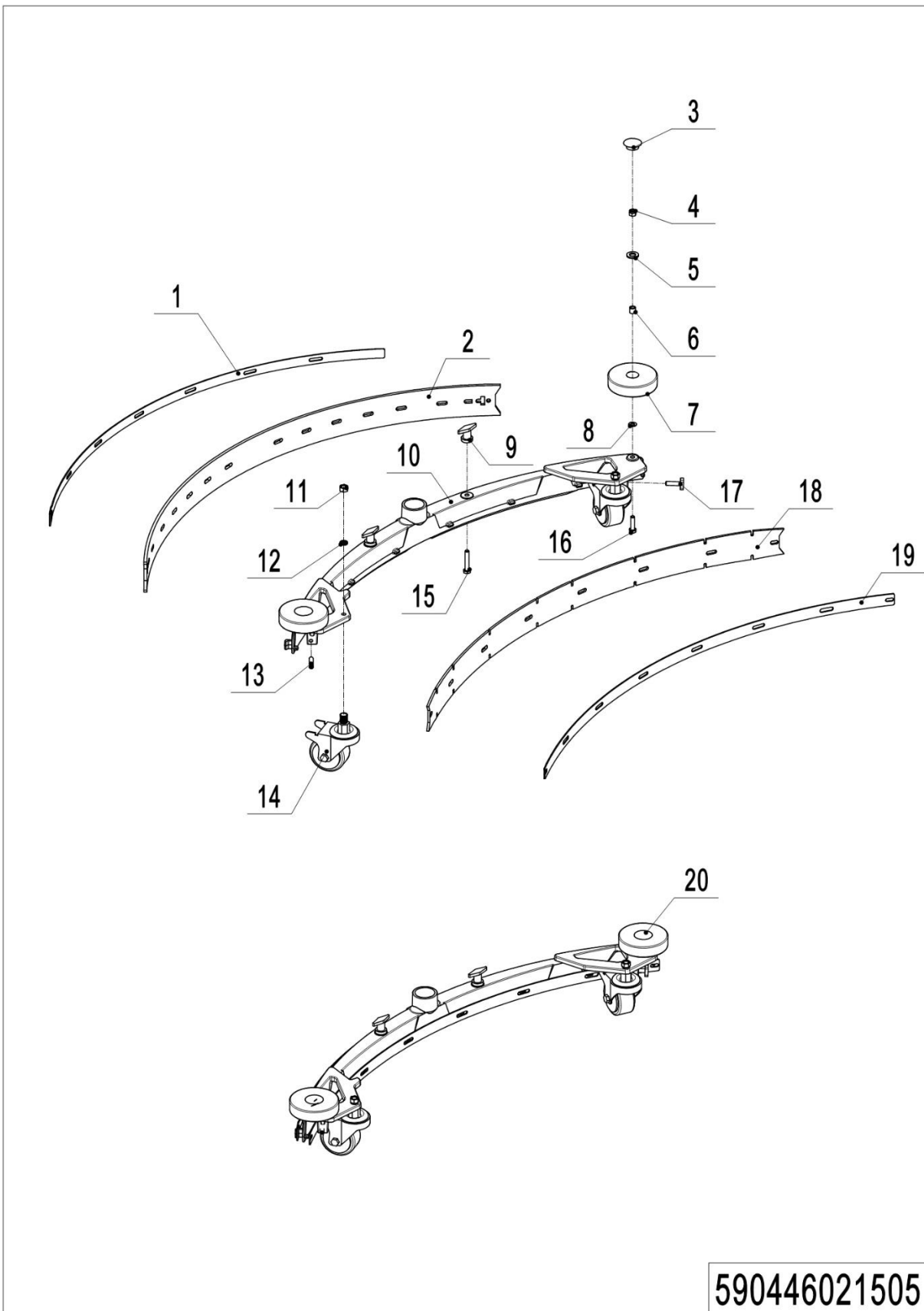
05 Squeegee system (590446021505)

05 Squeegee system (590446021505)

No.	Item Code	Mark	Item Description	Qty.	Substitute	Note
1	590498520093		REAR HOLDER BLADE	1		
2	590498520094		BLADE REAR RUBBER	1		
2	590498520116		BLADE REAR NR	1		OPTIONAL
2	590498520117		BLADE REAR PU	1		OPTIONAL
3	590498520139		COVER	2		
4	590198520066		NUT HEX SELF LOCKING M8	2		
5	590198520109		WASHER D8×D24×2	2		
6	590498520140		SPACER	2		
7	590498520096		WHEEL	2		
8	590498520143		WASHER FLAT D8×D13×0.5	2		
9	590498520092		HANDLE	2		
10	590498520089		SQUEEGEE BLADE	1		
11	590498520141		NUT M12	2		
12	590198520073		WASHER SPRING M10	2		
13	590198520149		SCREW M8×35	2		
14	590498520095		CASTER	2		
15	590498520142		SCREW HEX HD M8×45	2		
16	590198520145		SCREW HEX HD M8×30	2		
17	590198520148		SCREW M8×30	1		
18	590498520090		BLADE FRONT RUBBER	1		
18	590498520114		BLADE FRONT NR	1		OPTIONAL
18	590498520115		BLADE FRONT PU	1		OPTIONAL
19	590498520091		FRONT HOLDER BLADE	1		
20	590498510012		SQUEEGEE ASSEMBLY	1		W/O BLADE

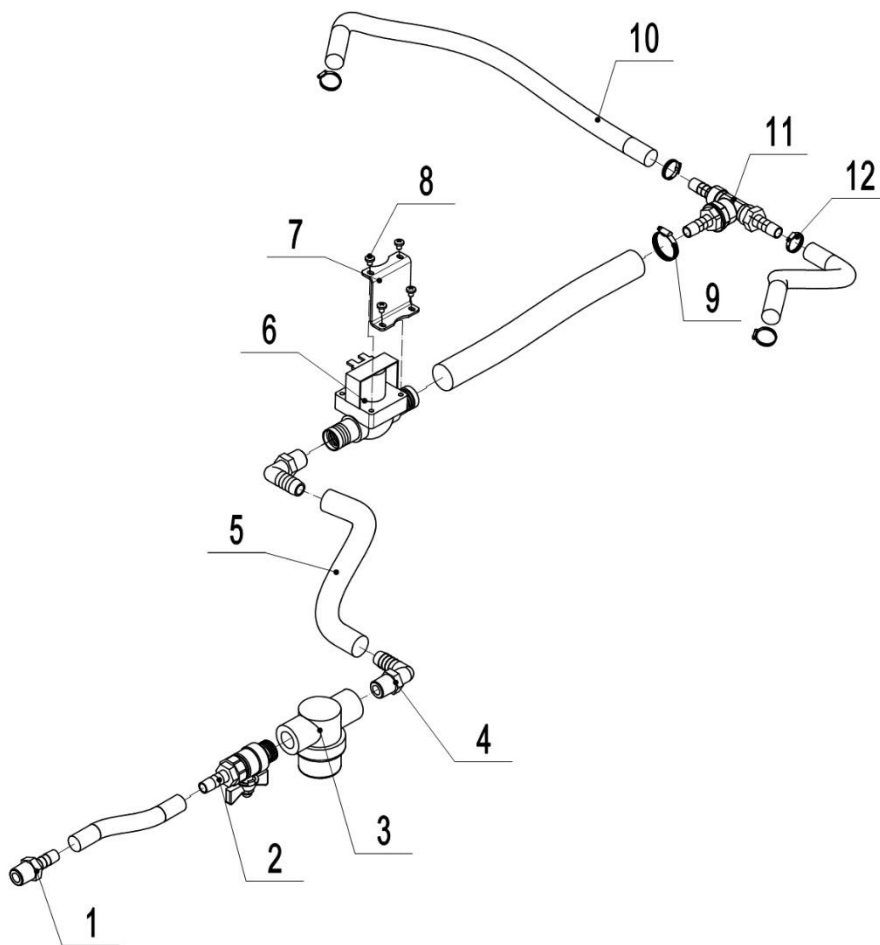
06 Solution assembly (590446021506)**590446021506**

06 Solution assembly (590446021506)

No.	Item Code	Mark	Item Description	Qty.	Substitute	Note
1	590498520018		CONNECTOR Ø19	2		
2	590498520080		VALVE	1		
3	590498520024		FILTER	1		
4	590498520019		CONNECTOR Ø19	1		
5	590498520015		HOSE Ø19	1		1m
6	590498510007		SOLENOID VALVE 24V	1		
7	590498520031		HOLDER FOR SOLENOID	1		
8	590198520092		SCREW CYL HD M4x12	2		
9	590498520076		HOSE CLAMP D19-29	4		
10	590198520062		HOSE PVC	0.8		0.8m
11	590498520014		CONNECTOR	1		
12	590198520096		HOSE CLAMP D13-19	4		

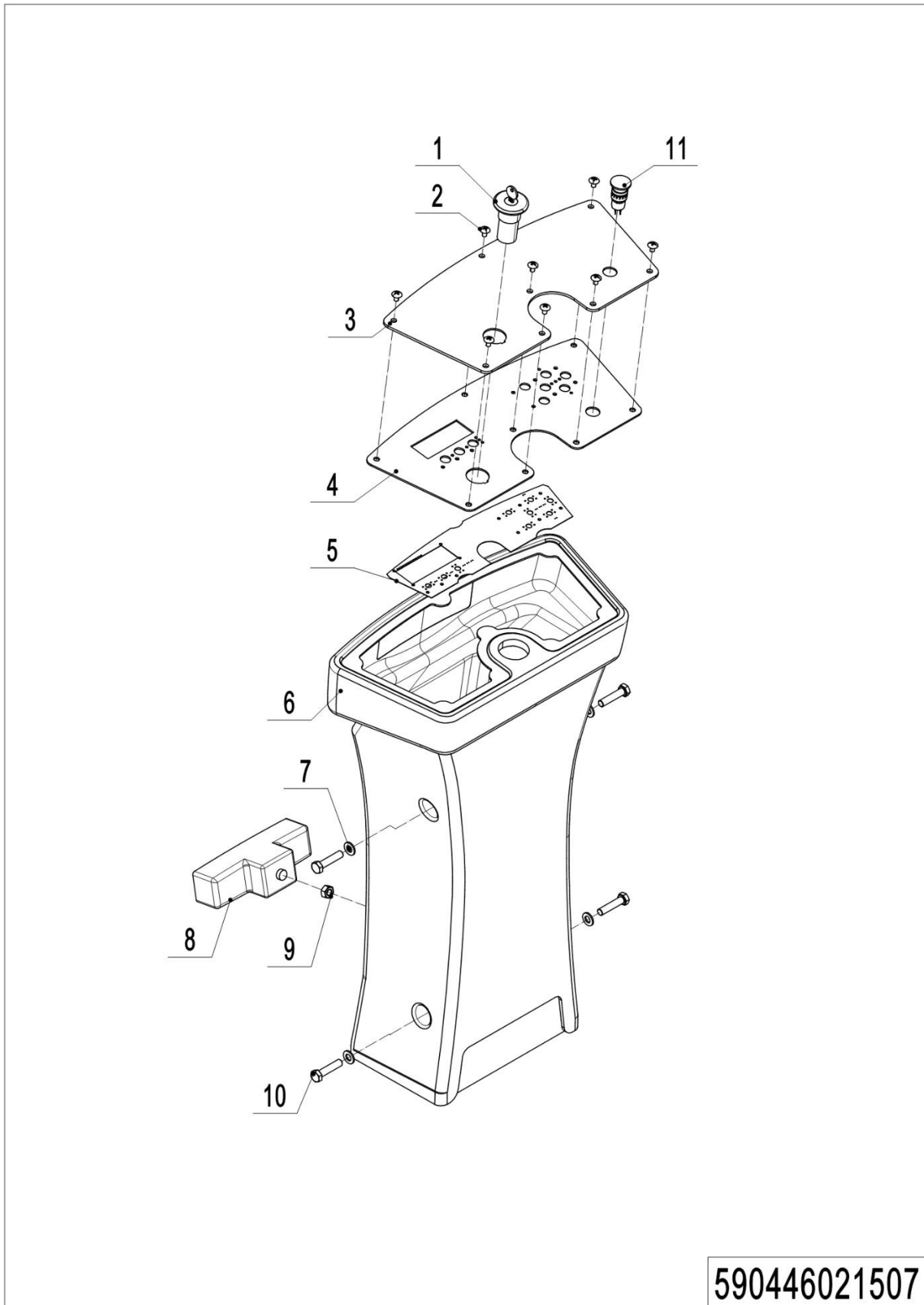
07 Front body (590446021507)

07 Front body (590446021507)

No.	Item Code	Mark	Item Description	Qty.	Substitute	Note
1	590398510004		START SWITCH WITH KEY	1		
2	590198520093		SCREW CYL HD M5x12	8		
3	590498520001		DECAL FOR CONTROL	2		
4	590498520045		CONTROL PANEL	1		
5	590498520129		PCB CONTROL PANEL	1		
6	590498520021		FRONT COVER	1		
7	590398520002		WASHER D8xD30x2.5	4		
8	590398510009		LED LIGHT	1		
9	590198520071		NUT M6 SS	1		
10	590498520130		SCREW SOCKET HD M8x35	4		
11	590398510008		EMERGENCY SWITCH	1		

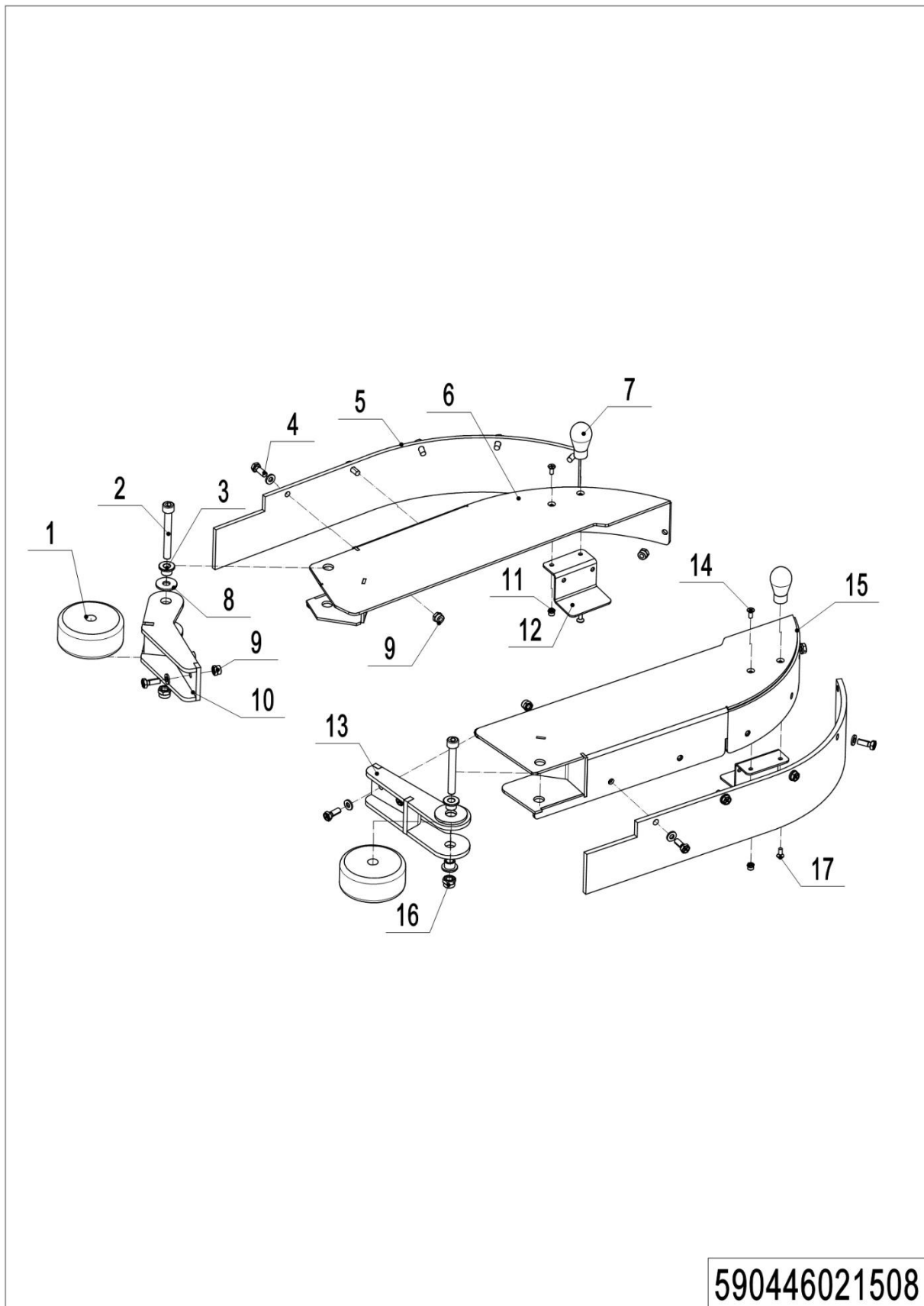
08 Retaining edge (590446021508)

08 Retaining edge (590446021508)

No.	Item Code	Mark	Item Description	Qty.	Substitute	Note
1	590498520023		FENDER WHEEL	2		
2	590498520069		SCREW SOCKET HD M8X65	2		
3	590398520072		SPACER D8xD12x10	8		
4	590198520142		SCREW M6x16 W WASHER	12		
5	590498520007		BRUSH FOR WATER FENDER	2		
6	590498520036		RIGHT WING	1		
7	590498520075		LIFTING	2		
8	590398520085		WASHER FLAT D12xD24x2.5	2		
9	590198520067		NUT HEX SELF LOCKING M6	16		
10	590498520027		RIGHT BRACKET	1		
11	590498520079		NUT HEX SELF LOCKING M4	2		
12	590498520038		PLATE	2		
13	590498520026		LEFT BRACKET	1		
14	590498520064		SCREW SOCKET HD M4x16	2		
15	590498520035		LEFT WING	1		
16	590198520066		NUT HEX SELF LOCKING M8	2		
17	590198520092		SCREW CYL HD M4x12	2		

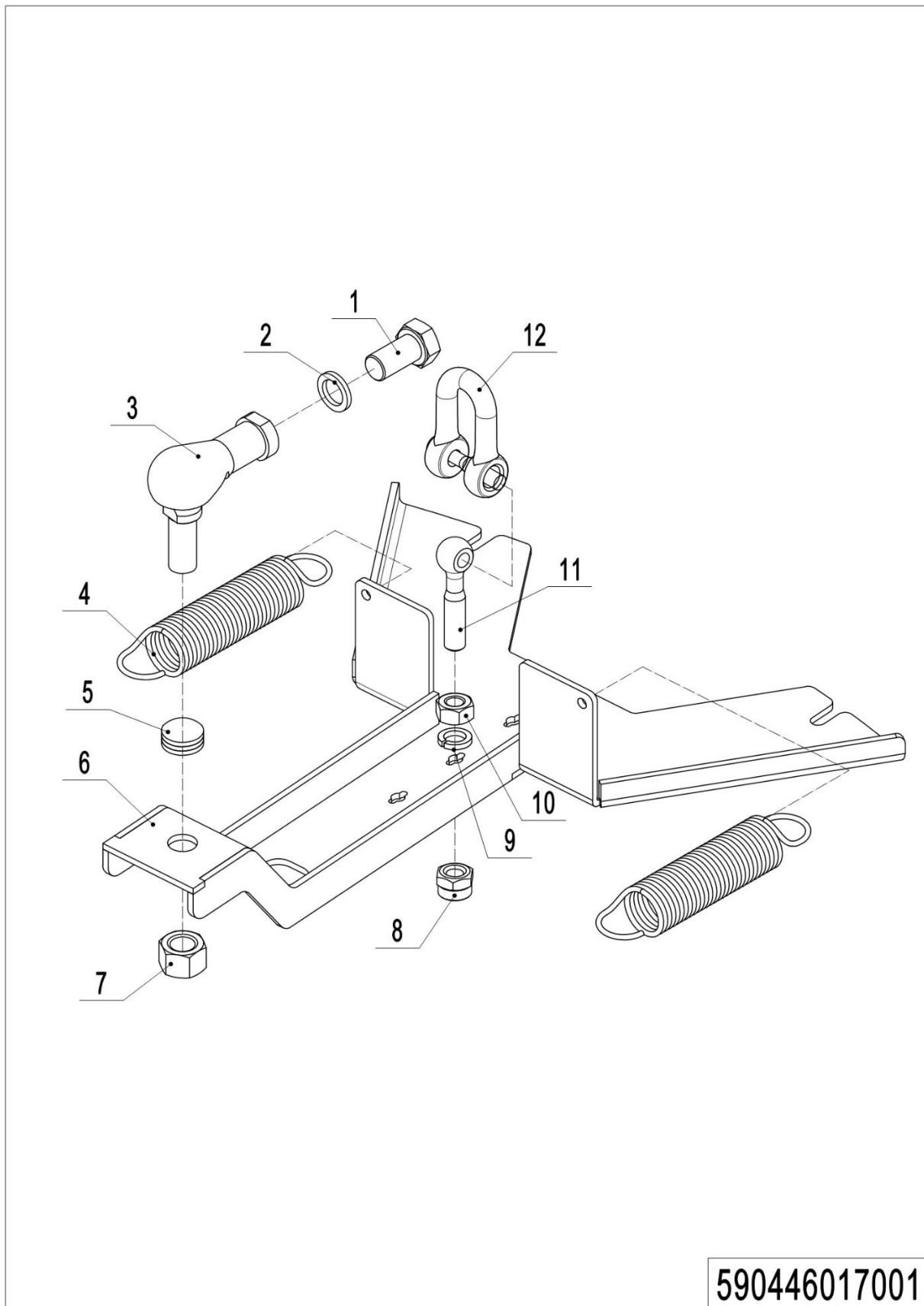
09 Wiper frame (590446017001)**590446017001**

09 Wiper frame (590446017001)

No.	Item Code	Mark	Item Description	Qty.	Substitute	Note
1	590398520058		SCREW HEX HD M16x25	1		
2	590398520086		WAHSER SPLIT M16	2		
3	590398520066		BALL BARING M16	1		
4	590498520078		SPRING	2		
5	590398520053		WASHER FLAT Ø16	6		
6	590498520028		HOLDER FOR SQUEEGEE	1		
7	590398520063		NUT M16	1		
8	590198520066		NUT HEX SELF LOCKING M8	1		
9	590198520074		WAHSER SPLIT M8 SS	1		
10	590198520122		THIN NUT M8	1		
11	590498520120		FISEYE SCREW M8x55	1		
12	590498520121		LIFTING RING M6	1		

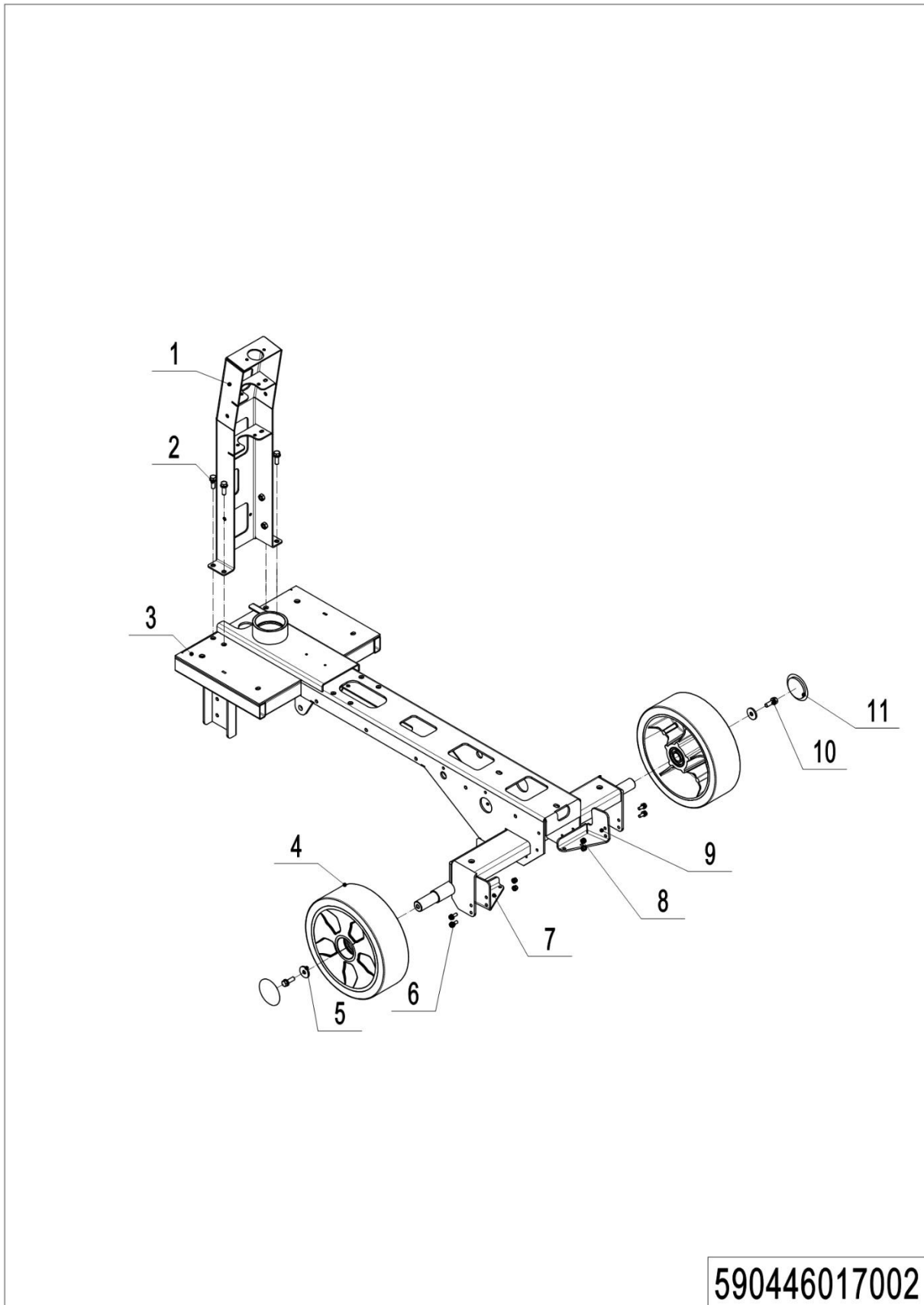
10 Wheels (590446017002)

10 Wheels (590446017002)

No.	Item Code	Mark	Item Description	Qty.	Substitute	Note
1	590498510003		UPRIGHT	1		
2	590398520057		SCREW M8x16 W WASHER	4		
3	590498510002		FRAME	1		
4	590498520025		REAR WHEEL 250	2		
5	590398520002		WASHER D8xD30x2.5	2		
6	590398520048		SCREW M6x20 W WASHER	4		
7	590498520122		LEFT SUPPORT	1		
8	590198520067		NUT HEX SELF LOCKING M6	1		
9	590498520123		RIGHT SUPPORT	1		
10	590198520069		SCREW M8x20 W WASHER	2		
11	590498520131		REAR WHEEL 250	2		

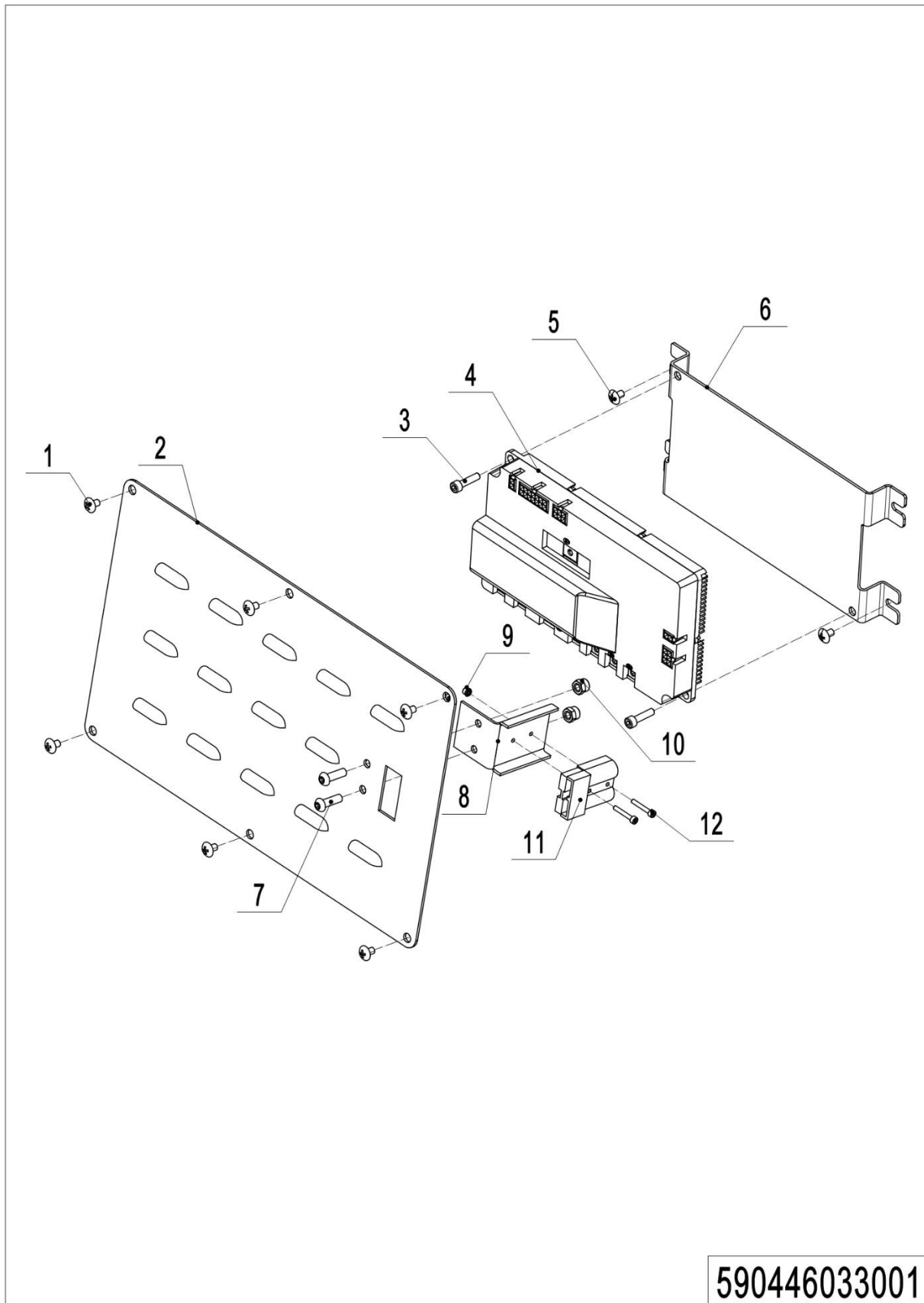
Chapter 3: Electrical parts**01 Electronic control components (590446033001)**

1= Supply as package. 2= Supply with constraints. 3= Phasing-out supply. 4= Supply as assembly. 5= Check other tables.

01 Electronic control components (590446033001)

No.	Item Code	Mark	Item Description	Qty.	Substitute	Note
1	590198520093		SCREW CYL HD M5x12	6		
2	590398520028		COVER	1		
3	590398520079		SCREW CYL HD M5x20	2		
4	590498510015		ELECTRIC BOARD	1		
5	590198520093		SCREW CYL HD M5x12	2		
6	590398520035		HOLDER	1		
7	590198520093		SCREW CYL HD M5x12	2		
8	590398520032		HOLDER	1		
9	590198520102		NUT HEX SELF LOCKING M3	4		
10	590198520068		NUT HEX SELF LOCKING M5	2		
11	590198520183		MICROSWITCH	1		
12	590198520141		CHARGER WIRE	1		
13	590398520078		SCREW CYL HD M3x20	4		

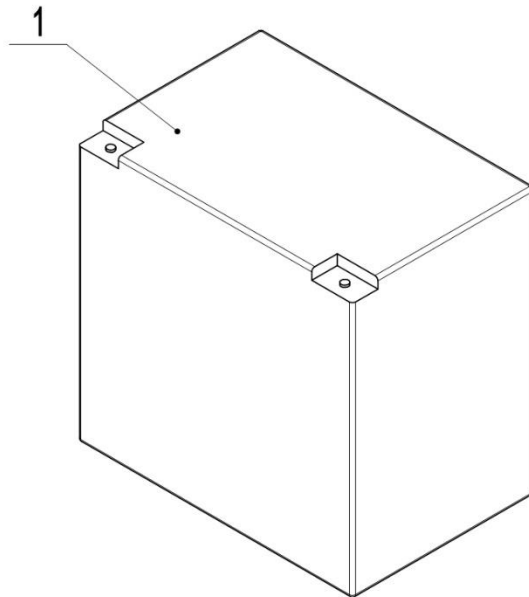
02 Traction Battery (590446037001)

590446037001

02 Traction Battery (590446037001)

No.	Item Code	Mark	Item Description	Qty.	Substitute	Note
1	590498520100		BATTERY 6V200AH	4		

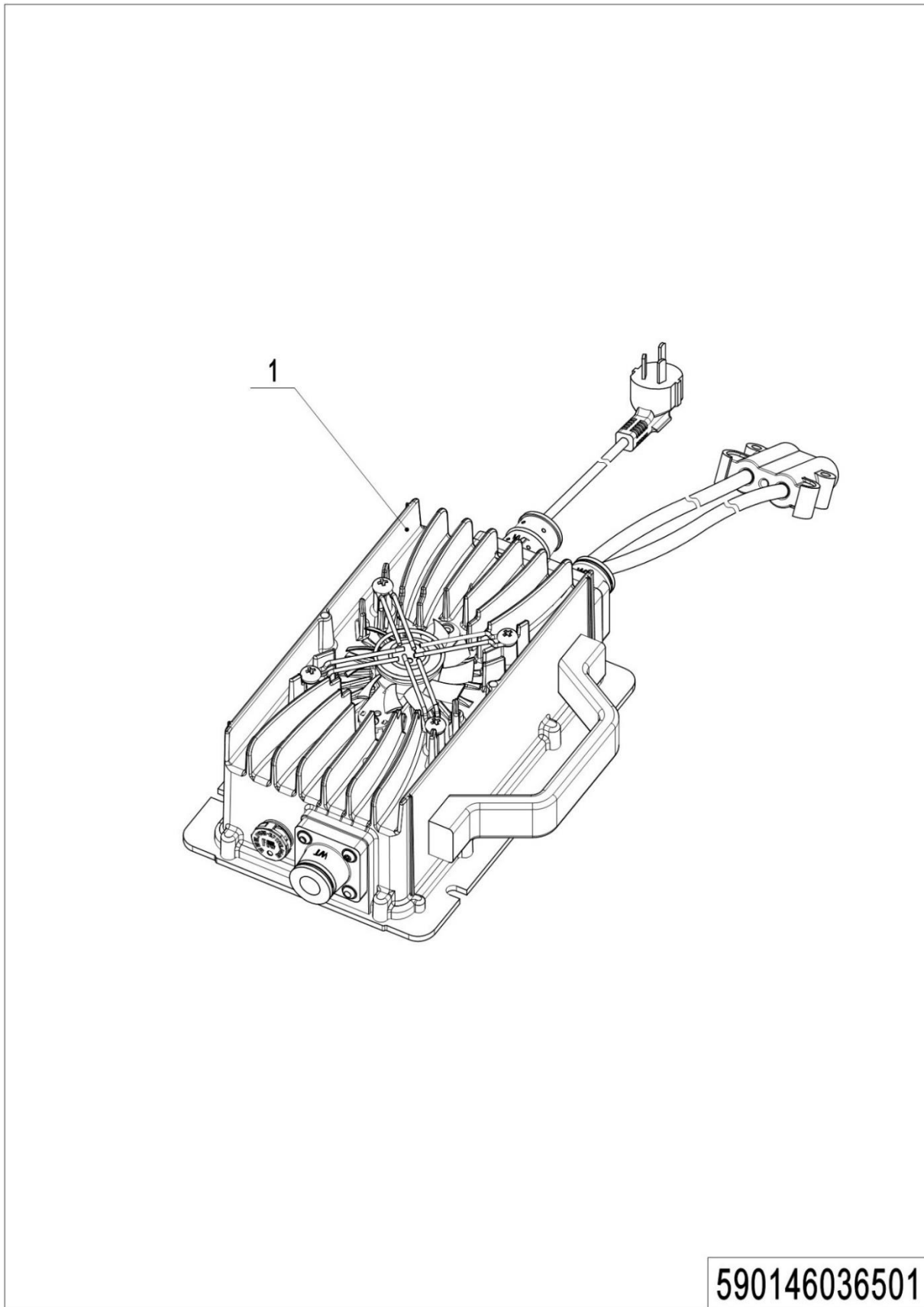
03 Charger (590446036501)

03 Charger (590446036501)

No.	Item Code	Mark	Item Description	Qty.	Substitute	Note
1	590498520101		CHARGE 24V25A(Asia)	1		
2	590498520102		CHARGE 24V25A(ENG)	1		
3	590498520103		CHARGE 24V25A(US)	1		
4	590498520104		CHARGE 24V25A(EU)	1		
5	590498520105		CHARGE 24V25A(AUS)	1		
6	590498520106		CHARGE 24V25A(ITA)	1		
7	590498520107		CHARGE 24V25A(SWE)	1		
8	590498520108		CHARGE 24V25A(ISR)	1		
9	590498520109		CHARGE 24V25A(BRA)	1		

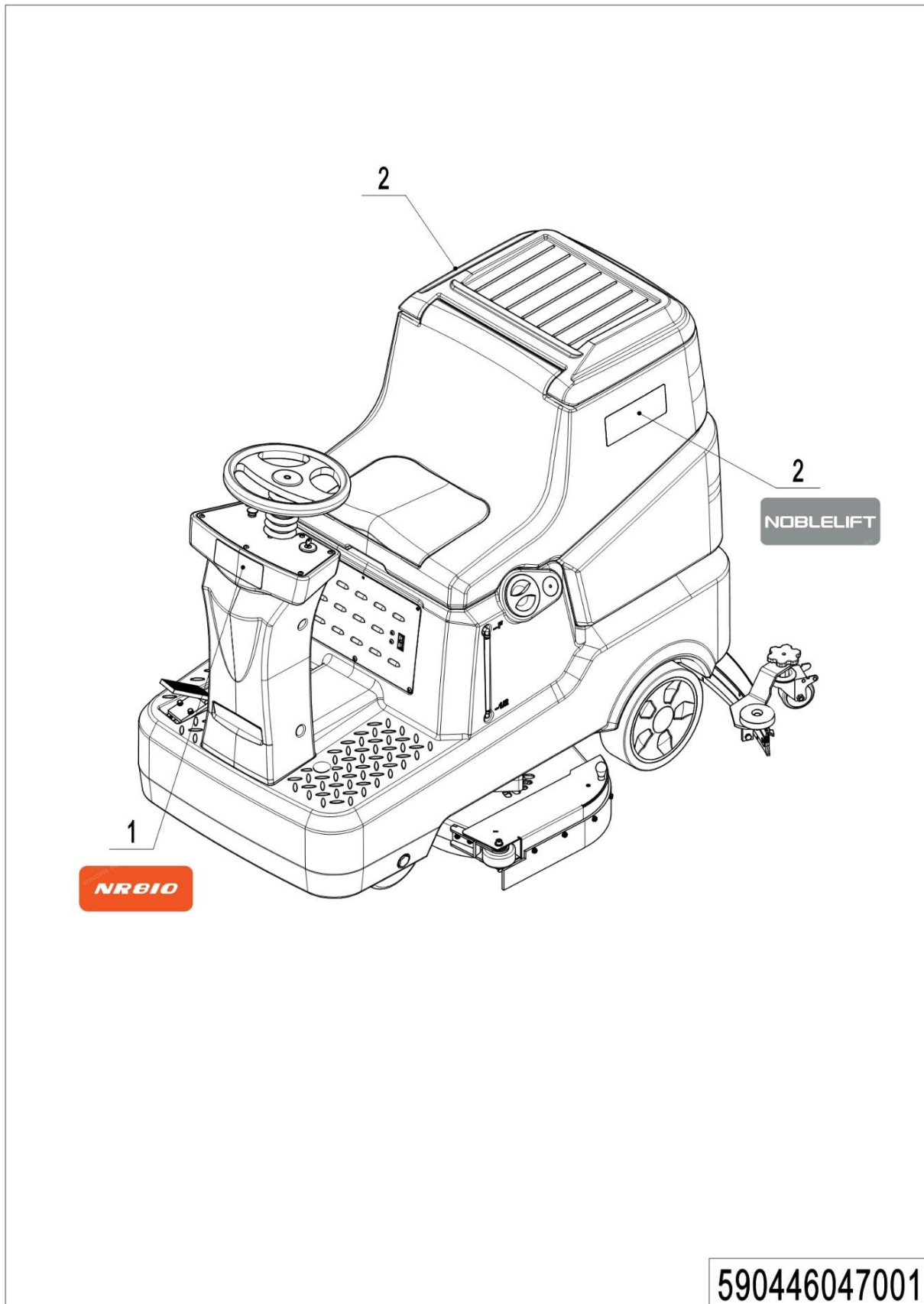
Chapter 4: Others**01 Labels and decals (590446047001)**

01 Labels and decals (590446047001)

No.	Item Code	Mark	Item Description	Qty.	Substitute	Note
1	590498520110		LABLE(NR810)	1		
2	590498520111		LABLE(NOBLELIFT)	2		

Appendix

01 Electrical Circuit Diagram (509946045502)

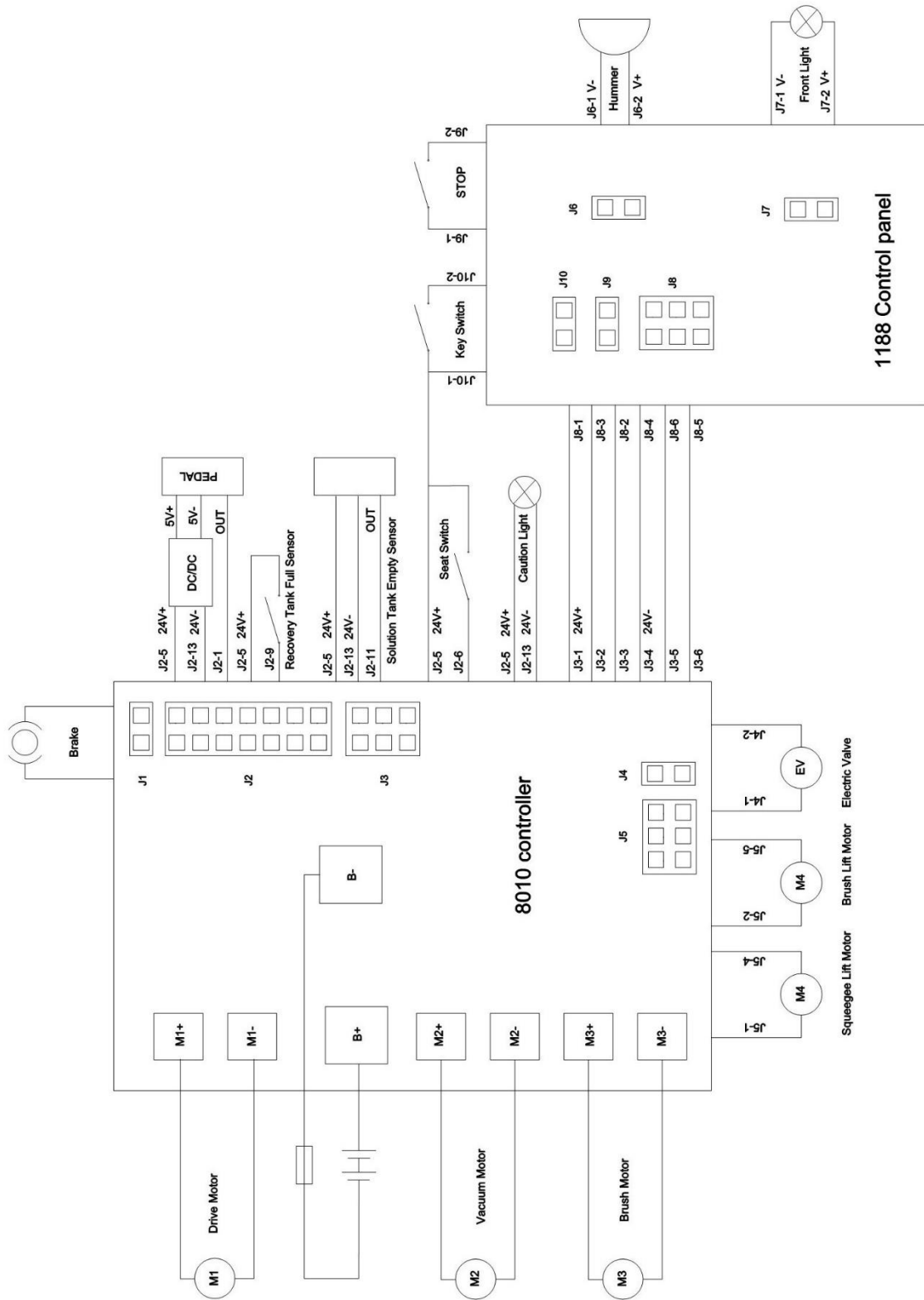

1= Supply as package. 2= Supply with constraints. 3= Phasing-out supply. 4= Supply as assembly. 5= Check other tables.

02 Easy Wornout Parts List

No.	Item Code	Item Description	Qty.	Chapter/ Section/ Number
1	590498520050	STEERING WHEEL COVER	1	Chapter 1/01/04
2	590398510006	ACCELERATOR	1	Chapter 2/01/01
3	590398510010	ALARM LIGHT	1	Chapter 2/01/17
4	590498510009	REAR PUSH MOTOR	1	Chapter 2/01/28
5	590198520061	GASKET	1.45	Chapter 2/02/05
6	590498520055	DRAIN HOSE	1	Chapter 2/02/07
7	590498520054	VACUUM HOSE	1	Chapter 2/02/09
8	590198520015	FLOATING BALL	1	Chapter 2/02/10
9	590198520014	CAGE FOR FLOATING BALL	1	Chapter 2/02/11
10	590398520043	SEAT	1	Chapter 2/02/12
11	590398510001	SENSOR FOR SEAT	1	Chapter 2/02/13
12	590498510008	VACUUM MOTOR 24V	1	Chapter 2/02/23
13	590498510005	REDUCTION GEARMOTOR LH	1	Chapter 2/03/01
14	590498510006	REDUCTION GEARMOTOR	1	Chapter 2/03/02
15	590498510004	FRONT PUSH MOTOR	1	Chapter 2/04/05
16	590498520096	WHEEL	2	Chapter 2/05/07
17	590498520095	CASTER	1	Chapter 2/05/14
18	590498510012	SQUEEGEE ASSEMBLY	2	Chapter 2/05/20
19	590498520080	VALVE	1	Chapter 2/06/02
20	590498520024	FILTER	1	Chapter 2/06/03
21	590498510007	SOLENOID VALVE 24V	1	Chapter 2/06/06
22	590398510004	START SWITCH WITH KEY	1	Chapter 2/07/01
23	590398510009	LED LIGHT	1	Chapter 2/07/08
24	590398510008	EMERGENCY SWITCH	1	Chapter 2/07/11
25	590498520023	FENDER WHEEL	2	Chapter 2/08/01
26	590498520007	BRUSH FOR WATER FENDER	2	Chapter 2/08/05
27	590498520025	REAR WHEEL 250	2	Chapter 2/10/04

03 Consumable Parts List

No.	Item Code	Item Description	Qty.	Chapter/ Section/ Number
1	590498510013	BRUSH	2	Chapter 2/03/10
	590498520112	BRUSH (SOFT)	2	Chapter 2/03/10
	590498520113	BRUSH (HARD)	2	Chapter 2/03/10
	590498510014	MAGNETIC PAD	2	Chapter 2/03/10
2	509498520094	BLADE REAR RUBBER	1	Chapter 2/05/02
	590498520116	BLADE REAR NR	1	Chapter 2/05/02
	590498520117	BLADE REAR PU	1	Chapter 2/05/02
3	509498520090	BLADE FRONT RUBBER	1	Chapter 2/05/18
	590498520114	BLADE FRONT NR	1	Chapter 2/05/18
	590498520115	BLADE FRONT PU	1	Chapter 2/05/18
4	590498520118	WHITE PAD	1	USE WITH PAD DRIVER
	590498520119	BLACK PAD	1	USE WITH PAD DRIVER